



**专注成就专业，品质提升效率**

Focus on mining, Expert in Carbide



**Zhuzhou Kimberly Carbide Company Limited**

Add1: No.336 Lujiang Road, Tianyuan District, Zhuzhou, Hunan. China

Add2: No.158 Jinjing Road, Hetang District, Zhuzhou, Hunan, China

Tel/Fax : +86-731-28254576 Cell: +86 13407330558

Email: johnny@kbcarbide.com / kbcarbide@163.com

Web site: www.kbcarbide.com



**株洲金佰利硬质合金有限公司**  
ZHUSHOU KIMBERLY CARBIDE CO.,LTD





# CORPORATE CULTURE

## 企业文化

株洲·嘉德工业园



## 目录 contents

- ▣ 公司简介 1
- ▣ Company profile
- ▣ 先进工艺装备 2
- ▣ Advanced process equipment
- ▣ 技术研发实力 3
- ▣ Technological prowess
- ▣ 矿山开采齿 4
- ▣ Insert inlaid in inhole drill for Mining
- ▣ 油田牙轮钻齿 8
- ▣ Tri-cone drilling bits for oil field
- ▣ 煤田采掘齿 11
- ▣ Insert for coal mining
- ▣ 工程掘进齿 13
- ▣ Insert for construction
- ▣ 复合片基体 15
- ▣ Matrix of Composite Insert with Diamond
- ▣ 盾构刀具合金 16
- ▣ Alloy cutting tools on shields

**企业愿景：**到2038年前成为中国领先全球一流的硬质合金产品提供商。

**企业使命：**为全球用户提供高品质硬质合金产品及服务。

**价值观：**诚信、负责、开放、共赢。

**服务理念：**全心全意服务客户，为客户创造更多价值。

**企业精神：**创新、务实、团结、敬业。

创新 务实 团结 敬业  
Unity and dedication to practical innovation

金佰利硬质合金  
KIMBERLY CARBIDE



## 公司简介 Company profile

株洲金佰利硬质合金有限公司坐落于中国硬质合金之都——株洲，是一家集科研、设计、生产和整体合金解决方案为一体的高新技术型企业。公司采用国际领先的硬质合金生产工艺设计建设，拥有可倾斜球磨机、闭式喷雾干燥塔、TPA自动压力机、压力脱蜡烧结一体炉、金相显微镜、悬臂式球磨实验机以及PS21试验压机等先进生产研发检测设备30余台套。

金佰利公司研发技术实力雄厚，主要技术骨干具有近二十年硬质合金生产、研发、管理经验，公司总经理卿林先生在硬质合金从业期间获各类国家级、省部级、市级奖励五项，发明专利二项，实用新型专利三项。其作为行业领军人物主持国家某型直升机用硬质合金关键零部件项目攻关成功，成果获湖南省国防科学技术进步奖一等奖。

我司秉承“客户至上，质量为本”的理念，专注钻掘类钻具球齿、旋挖齿、煤截齿、铣刨齿、盾构刀具用硬质合金生产研发，致力为全球用户提供高品质硬质合金产品及服务，和新老客户一起共赢共荣、共创辉煌。

Zhuzhou Kimberly Carbide Company is the highly technological contains research, designing, selling and integrated solutions, and lies in Zhuzhou High Technology Area where famous as the largest cemented carbide city in the world.

Absorbing advance technology and sophisticated equipments, such as inclined ball mill, closed spray drying tower, TPA automatic press, pressure de-waxing and sintering integral furnace, metallographic microscope, cantilever type ball-milling experimental machine and PS21 testing machine and the like.

Kimberly as the fast developing company has extremely experienced team in the field of cemented carbide who were average over 20 years. Mr. Qing, the CEO, did great contributions to its major as the first price about participating in a national helicopter project.

Kimberly sincerely hope providing all clients with excellent products and professional service from all over the world. And the main mining products including Hard alloy is adopted for the production and development of rotary drilling ball-tooth bit, auger bit, coal mining bit, gear-shaping bit and shield cutter.

## 先进工艺设备 Advanced process equipment

公司充分引进吸收国际领先的硬质合金生产工艺技术设计建设，拥有300立升可倾斜球磨机、闭式喷雾制粒干燥塔、TPA自动压力机、脱蜡压力烧结一体炉、自动喷砂和钝化处理设备及金相显微镜等一系列生产质控保障设备，确保产品生产工艺的先进性和产品品质稳定可靠。

The company fully introduces and absorbs the leading international cemented carbide production technology and technology design and construction. It has 300 liter tilted ball mill, closed spray granulating drying tower, TPA automatic press, dewaxing pressure sintering integrated furnace, automatic sandblasting and passivation treatment equipment and metallographic microscope, and a series of production quality control safeguard equipment which ensures the progressiveness of the product production technology and quality of the product is stable and reliable .





## 技术研发实力 Technological prowess

公司主要技术骨干多次主持或参与国家“863”和“985”科研子项目研发，成果多次获得各类国家级、省部级、市级奖励；公司配备实验球磨机、PS21实验压机、金相检测仪等全套研发设备及辅助分析设备，技术研发实力居于行业前列。



The company fully introduces and absorbs the leading international cemented carbide production technology and technology design and construction. It has 300 liter tilted ball mill, closed spray granulating drying tower, TPA automatic press, dewaxing pressure sintering

integrated furnace, automatic sandblasting and passivation treatment equipment and metallographic microscope, and a series of production quality control safeguard equipment which ensures the progressiveness of the product production technology and quality of the product is stable and reliable .

## 矿山开采齿

### Insert inlaid in inhole drill for Mining

#### 材质介绍 MATERIAL INTRODUCTION

牌号 Grade	密度 Density (g/cm <sup>3</sup> )	矫顽磁力 Coercive force (KA/m)	硬度 Hardness HRA	抗弯强度 TRS (Mpa)	推荐用途 Applications recommended
KD102	14.93	11.2-12.7	90	2500	低风压潜孔钻头齿，适用于中软岩层；小直径热镶或冷压的锥孔连接钻头，适用于中、硬岩层。 Inhole drill for drilling mid-soft rock formation under a lower pressure. For the drill of mid-hard or hard rock formation with smaller diameter of drill connected by conical hole with heating mounting or cold pressure mounting.
KD102H	14.95	11.7-12.7	90.5	2900	高压潜孔钻头齿，适用于硬、坚硬岩层；液压螺纹钻头用齿，适用于硬、坚硬岩层。 on the hard and ultra hard rock formation under high pressure. Mounted to hydraulic pressure helical drill to drill the hard and ultra hard rock formation.
KD203	14.70	8.0-10.0	89.2	2800	主要用于焊接类小直径钻头，适用于铁矿、金属矿、煤矿的掘进与开采；可用于大直径低风压潜孔钻头齿，适用于岩层复杂的中软岩层。 Used mainly for the brazed smaller diameter drill to excavate and mine the ferrous and other metallic ore as well as coal mine. Applied to mount on the larger diameter inhole drill to drill the mid-soft complicated rock formation under a lower pressure.
KD303	14.53	6.5-8.5	87.5	2900	适用于大直径潜孔钻用齿，钻进中硬、硬岩层。 Applied to mount on the inhole drill with bigger diameter to drill mid-hard and hard rock formation.
KD323	14.41	5.5-7.5	87.0	2900	适应于高强度，高冲击韧性的异形钻头；岩层复杂的坚硬岩层。 In use for making the special drill to drill the ultra hard rock formation with complicated structure in which the high strength and high impact toughness of drill are required.

注：产品材质可根据客户需求定制开发。  
products material can be customized and developed according to customer needs.

## 矿山开采齿 Insert inlaid in hole drill for Mining

### 球型齿 Spherical Insert

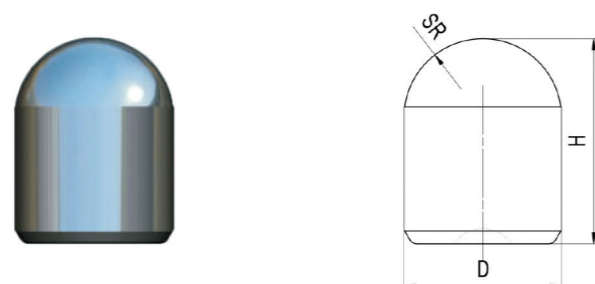

产品型号 Type	基本尺寸 Dimensions		
	直径 Diameter	高度 Height	球半径 Radius
SQ0812	8.20	12.00	4.3
SQ0913	9.20	14.00	4.7
SQ1014	10.20	15.00	5.2
SQ1116	11.20	16.00	6.0
SQ1217	12.20	17.00	6.6
SQ1318	13.20	20.00	6.7
SQ1419	14.20	20.00	7.3
SQ1621	16.30	21.00	8.7
SQ1826	18.30	26.00	9.3
可按照客户要求的尺寸及形状生产 Can be produced according to the size and shape required by the customer			

## 矿山开采齿 Insert inlaid in hole drill for Mining

### 锥型齿 Conical Insert

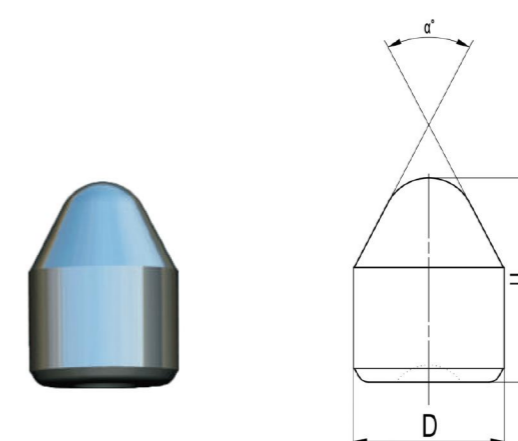

产品型号 Type	基本尺寸 Dimensions		
	直径 Diameter	高度 Height	角度 Angle
SZ0812	8.20	12.20	58
SZ1015	10.20	15.20	55
SZ1217	12.20	17.20	55
SZ1318	13.20	18.20	55
SZ1419	14.20	19.20	55
SZ1520	15.30	20.30	55
可按照客户要求的尺寸及形状生产 Can be produced according to the size and shape required by the customer			



## 矿山开采齿 Insert inlaid in hole drill for Mining

### 抛物线型齿 Parabolic Insert

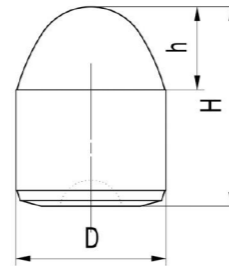

产品型号 Type	基本尺寸 Dimensions		
	直径 Diameter	高度 Height	冠高 Crest Height
SD0711	7.20	11.00	3.90
SD0812	8.20	12.00	4.50
SD0913	9.20	13.00	5.00
SD1015	10.20	15.00	5.30
SD1116	11.20	16.00	5.90
SD1217	12.30	17.00	7.30
SD1319	13.20	19.00	6.50
SD1422	14.30	22.00	7.30
可按照客户要求的尺寸及形状生产 Can be produced according to the size and shape required by the customer			

## 油田牙轮钻齿 Tri-cone drilling bits for oil field

### 材质介绍 MATERIAL INTRODUCTION

牌号 Grade	密度 Density (g/cm <sup>3</sup> )	矫顽磁力 Coercive force (KA/m)	硬度 Hardness HRA	抗弯强度 TRS (Mpa)	推荐用途 Applications recommended
KD603	13.95	4.5-6.0	85.5	2700	用于露齿高、齿形结构复杂的合金齿；钻头钻压较高的合金齿；适用于坚硬或较复杂的地质条件。 The insert that the open head is higher and the profile is complicated. The pressure on drill is higher. The rock formation is ultra hard and complicated.
KD453	14.20	5.3-7.2	86.0	2800	用于合金齿露齿中等，中等钻压的钻头；适用于中硬或硬的地质条件。 Both of the height of open head of insert and the drilling pressure are in the middle. For drilling the mid-hard or hard rock formation.
KD353	14.42	5.5-8.0	87.5	3000	用于露齿矮、齿形结构简单的合金齿；适用于中硬或偏软的地质条件。 The insert that the open head is shorter and the profile is simpler. 2. For drilling the mid-hard or close to soft rock formation.
KD602	13.95	5.8-8.3	86.8	3000	用于露齿高、齿形结构复杂的合金齿；钻头钻压较高的合金齿；适用于坚硬或较复杂的地质条件。产品耐磨性高于KD603。 The insert that the open head is higher and the profile is complicated. The pressure on drill is bigger. Applied to the ultra hard and complicated rock formation. 4. Its wear resistance is higher than KD603.
KD452	14.20	6.8-8.8	87.5	3000	用于合金齿露齿中等，中等钻压的钻头；适用于中硬或硬的地质条件；产品耐磨性高于KD453。 Both of the height of open head of insert and the drilling pressure are in the middle. Applied to drill the mid-hard or hard rock formation. Its wear resistance is higher than KD453.
KD352	14.42	7.0-9.0	87.8	3000	用于露齿矮、齿形结构简单的合金齿；适用于中硬或偏软的地质条件；产品耐磨性高于KD353。 The Insert that the open head is shorter and the profile is simple. 2. For drilling the mid-hard or close to soft rock formation. 3. Its wear resistance is higher than KD353.
KD302	14.50	7.0-9.5	88.6	3000	用于合金齿露齿矮、齿形简单、钻压偏低的钻头；适用于硬岩或有色金属矿的开采。 For use in the drills of the shorter open head and simple profile of insert and lower drilling pressure. Applied to drill hard rock formation or nonferrous metals mine.
KD202	14.70	10.0-13.0	89.5	2600	用于保径齿、背齿、锯齿齿。 For use as diameter keep insert. Back insert, and serrate insert.

注：产品材质可根据客户需求定制开发。  
products material can be customized and developed according to customer needs.

## 油田牙轮钻齿 Tri-cone drilling bits for oil field

### 勺型齿 Spoon Insert

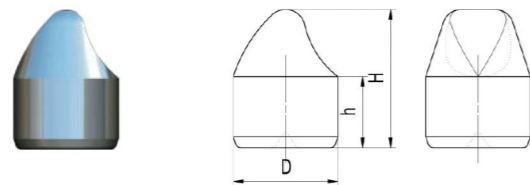

产品型号 Type	基本尺寸 Dimensions		
	直径 Diameter	高度 Height	柱高 Cylinder Height
SS1418-E20	14.20	18.00	9.90
SS1622-E20	16.20	22.00	11.00
SS1928-E25	19.20	28.00	14.00
可按照客户要求的尺寸及形状生产 Can be produced according to the size and shape required by the customer			

### 楔型齿 Wedge Insert

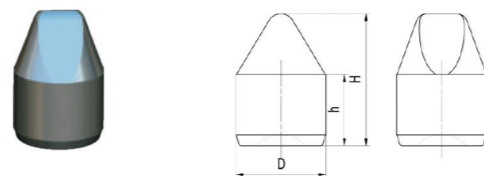

产品型号 Type	基本尺寸 Dimension		
	直径 Diameter	高度 Height	柱高 Cylinder Height
SX1014-E18	10.20	14.00	8.00
SX1318-E17Z	13.20	18.00	10.50
SX1418A-E20	14.20	18.00	10.00
SX1620A-E20	16.30	19.50	9.50
SX1724-E18Z	17.30	24.00	12.50
SX1827-E19	18.30	27.00	15.00
可按照客户要求的尺寸及形状生产 Can be produced according to the size and shape required by the customer			

## 油田牙轮钻齿 Tri-cone drilling bits for oil field

### 边楔型齿 Eccentric Wedge Insert

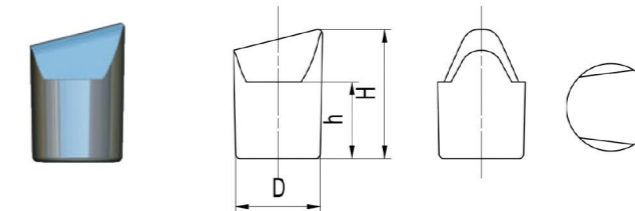

产品型号 Type	基本尺寸 Dimensions		
	直径 Diameter	高度 Height	柱高 Cylinder Height
SBX1217-F12Q	12.20	17.00	10.00
SBX1420-F15Q	14.20	20.00	11.80
SBX1624-F15Q	16.30	24.00	14.20
可按照客户要求的尺寸及形状生产 Can be produced according to the size and shape required by the customer			

### 平头齿 Flat Insert

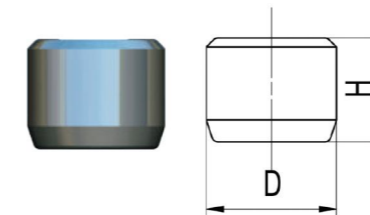

产品型号 Type	基本尺寸 Dimensions	
	直径 Diameter	高度 Height
SP0807-E15	8.20	6.90
SP1010-E20	10.20	10.00
SP1212-E18	12.20	12.00
SP1515-G15	15.20	15.00
可按照客户要求的尺寸及形状生产 Can be produced according to the size and shape required by the customer		

### 分背齿 Serrate Insert

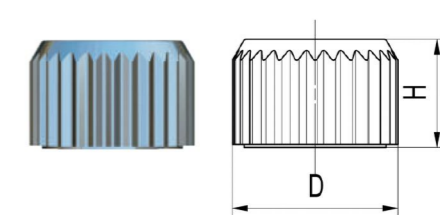

产品型号 Type	基本尺寸 Dimensions	
	直径 Diameter	高度 Height
SP0606F-Z	6.50	6.05
SP0805F-Z	8.10	4.75
SP0907F-Z	10.00	6.86
SP1109F-VR	11.30	8.84
SP12.909F-Z	12.90	8.84
可按照客户要求的尺寸及形状生产 Can be produced according to the size and shape required by the customer		



## 煤田采掘齿 Insert for coal mining

### 材质介绍 MATERIAL INTRODUCTION

牌号 Grade	密度 Density (g/cm <sup>3</sup> )	矫顽磁力 Coercive force (KA/m)	硬度 Hardness HRA	抗弯强度 TRS (Mpa)	推荐用途 Applications recommended
KD254	14.65	4.5-5.5	86.5	2500	主要用于软岩层的巷道掘进和含有煤矸石的煤层采掘。其耐磨性好，使用寿命长。 Used mainly for tunnel excavation in soft rock formation and mining the coal with coal gangue formation. It has good wear resistance and long life time.
KD304	14.50	4.0-5.0	86.0	2500	主要用于中硬岩层的巷道掘进和含有煤矸石的煤层采掘。其使用寿命较长、抗冲击韧性好。 Used mainly for tunnel excavation in mid-hard rock formation and mining the coal with coal gangue formation. It has long life time and good impact toughness.
KD354	14.40	3.5-4.5	85.5	2500	主要用于较硬岩层的巷道掘进、大直径采煤机滚筒用合金。其使用寿命长、抗冲击韧性好。 Used mainly for tunnel excavation on harder rock formation and mining the coal by the machine mounted with a big diameter of cylinder.
KD454	14.20	3.0-4.0	85	2500	适用于大型联合采煤机用截齿，其抗冲击性能好；适用于硬岩层的巷道掘进。 Applied to the mount on big combine machine mining coal. The insert has good impact toughness. Applied to tunnel excavation in hard rock formation.

注：产品材质可根据客户需求定制开发。  
products material can be customized and developed according to customer needs.

## 煤田采掘齿 Insert for coal mining

### 蘑菇型截齿 Mushroom Inserton Insert



产品型号 Type	基本尺寸 Dimensions		
	直径 Diameter	高度 Height	柱高 Cylinder Height
SM181022	18	10	22
SM201526	20	15	26
SM221437	22	14	37
SM302633	30	26	33
SM402253	40	22	53
可按照客户要求的尺寸及形状生产 Can be produced according to the size and shape required by the customer			

### 抛物线截齿 Parabolic Insert



产品型号 Type	基本尺寸 Dimensions	
	直径 Diameter	高度 Height
SMJ1621	16	21
SMJ1824	18	24
SMJ1925	19	25
SMJ2026	20	26
SMJ2127	21	27
可按照客户要求的尺寸及形状生产 Can be produced according to the size and shape required by the customer		

### 多锥形截齿 Multiple Cone Insert

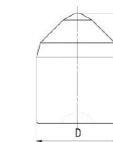

产品型号 Type	基本尺寸 Dimensions	
	直径 Diameter	高度 Height
SMJ1621MZ	16	21
SMJ1824MZ	18	24
SMJ1925MZ	19	25
SMJ2026MZ	20	26
SMJ2127MZ	21	27
可按照客户要求的尺寸及形状生产 Can be produced according to the size and shape required by the customer		



## 工程掘进齿 Insert for construction

### 材质介绍 MATERIAL INTRODUCTION

牌号 Grade	密度 Density (g/cm <sup>3</sup> )	矫顽磁力 Coercive force (KA/m)	硬度 Hardness HRA	抗弯强度 TRS (Mpa)	推荐用途 Applications recommended
KD104	14.95	5.5-6.5	87.0	2500	用于水泥路面的铣刨齿；用于较硬岩层的掘进机用齿，其抗冲击性能好。 1 Applied to mill and plane the concrete road surface. For the excavation of harder rock formation with a good impact toughness.
KD102H	14.95	11.7-12.7	90.5	2900	用于沥青路面的铣刨齿；用于中硬岩层的掘进机用齿，其耐磨性好。 For use as the insert to mill and plane the asphalt road surface. For excavation of mid-hard rock formation with good wear resistance.
KD253	14.65	6.2-8.7	88.0	2800	用于大直径的潜孔钻齿，钻进坚硬岩层；用于三牙轮矿用钻头钻进中软岩层，使用寿命长；用于软岩层的滚刀合金、盘刀合金。 Applied to mount on the big diameter of in-hole drill to drill the ultra hard rock formation. Mounted on the tri-cone drill for drilling the mid-soft rock formation with a long life time. Mounted on the hobbing and disc cutter to cut soft rock formation.
KD303	14.53	6.5-8.5	87.5	2900	用于三牙轮矿用钻头钻进中硬岩层，耐磨性较好；2. 用于中硬岩层的滚刀合金、盘刀合金。 For mounting on the tri-cone drill to cut the mid-hard rock formation with a better wear resistance. Mounted on the hobbing and disc cutter to cut mid-hard rock formation.
KD353	14.42	5.5-8.0	87.5	3000	用于三牙轮矿用钻头钻进硬岩层，抗冲击性能好；用于硬岩层的滚刀合金、盘刀合金；地铁盾构机刀具用各类合金；粉体辊压机用合金柱。 Mounted on the tri-cone drill to cut hard rock formation with a better impact toughness. Mounted on the hobbing and disc cutter to cut hard rock formation. Mounted on the boring cutter for boring the subway tunnel. Mounted on the roller of powder rolling machine.
KD254	14.65	4.5-5.5	86.5	2500	适用于较软岩层的巷道掘进截齿；露天沟渠的开挖，隧道的掘进，露天矿山的开采。 For use as a insert to excavate the softer rock formation tunnel. Used for the excavation of open trench and tunnel or the mining of open mine.
KD304	14.50	4.0-5.0	86.0	2500	1. 适用于较硬岩层的巷道掘进截齿；适用于水泥路面的铣刨用齿。 For use in the tunnel excavation in harder rock formation. Applied to mill and plane the concrete road surface.

注：产品材质可根据客户需求定制开发。  
products material can be customized and developed according to customer needs.

## 工程齿 Insert for construction

### 路面铣刨齿 Insert for Road Surface Milling and Planing



产品型号 Type	基本尺寸 Dimensions	
	直径 Diameter	高度 Height
KW185095017	18.5	17
KW190102184	19.0	18.4
KW200110220	20.0	22.0
可按照客户要求的尺寸及形状生产 Can be produced according to the size and shape required by the customer		

### 工程铣挖齿 Insert for Milling and Excavation in Construction



产品型号 Type	基本尺寸 Dimensions	
	直径 Diameter	高度 Height
KXW0812	8.0	12.0
KXW1217	12.0	17.0
KXW1319	13.0	19.0
KXW1624	16.0	24.0
KXW182	18.0	27.0
可按照客户要求的尺寸及形状生产 Can be produced according to the size and shape required by the customer		



## 金刚石复合片基体 Matrix of Composite Insert with Diamond

### 材质介绍 MATERIAL INTRODUCTION

牌号 Grade	密度 Density (g/cm <sup>3</sup> )	矫顽磁力 Coercive force (KA/m)	硬度 Hardness HRA	抗弯强度 TRS (Mpa)	推荐用途 Applications recommended
KD603	13.95	4.5-6.0	85.5	2700	适用于地质、煤田等金刚石复合片的基体。 For use as the matrix of composite with diamond in the geological prospecting and coal mining.
KD451	14.20	10.0-11.5	88.5	3000	适用于油田开采类金刚石复合片的基体。 For use as the matrix of composite with diamond in the recovering of oil.
KD452	14.20	6.8-8.8	87.5	3000	适用于 PDC 刀片的基体。 For use as the matrix of composite with PDC.
KD352	14.42	7.0-9.0	87.8	3000	适用于 PDC 刀片的基体。 For use as the matrix of composite with PDC.

注：产品材质可根据客户需求定制开发。  
products material can be customized and developed according to customer needs.

### 型号介绍 Model is introduced

产品型号 Type	基本尺寸 Dimensions		槽型 Surface Profile		
	直径 Diameter	高度 Height			
矿用复合片基体 Matrix of Composite Insert for Mining		KY12650	12.6	5.0	槽型和尺寸按用户要求定制 Groove shape and size are customized according to user requirements
		KY13842	13.8	4.2	
		KY14136	14.1	3.6	
		KY14439	14.4	3.9	
油田用复合片 基体 Matrix of Composite Insert for Oil Field		YT145273	14.52	7.3	
		YT17812	17.8	12.0	
		YT21519	21.5	19	
		YT26014	26.0	14	
复合刀片用 基体 Matrix of Composite Blade		PT27250	27.2	5.0	
		PT35041	35.0	4.1	
		PT50545	50.5	4.5	

注：可按照客户要求的尺寸及形状生产  
Can be produced according to the size and shape required by the customer

## 盾构刀具合金 Alloy cutting tools on shields

公司在盾构刀具合金上进行研发创新，摒弃传统橡胶成型剂、油压割型成型、真空烧结工艺，采用国际先进的石蜡成型剂、喷雾干燥制粒、TPA自动压制一次成型、脱蜡压力烧结一体工艺，生产出外观精致、性能优越的盾构刀具合金，深得用户好评。

The company carries out R & D innovation on the alloy of shield cutter, abandons the traditional rubber forming agent, oil pressure cutting molding and vacuum sintering process. It adopts the international advanced paraffin forming agent, spray drying granulating, TPA automatic pressing one time molding and dewaxing pressure sintering integrated process to produce the shield cutting alloys with fine appearance and superior performance. The alloys are highly praised by the users.

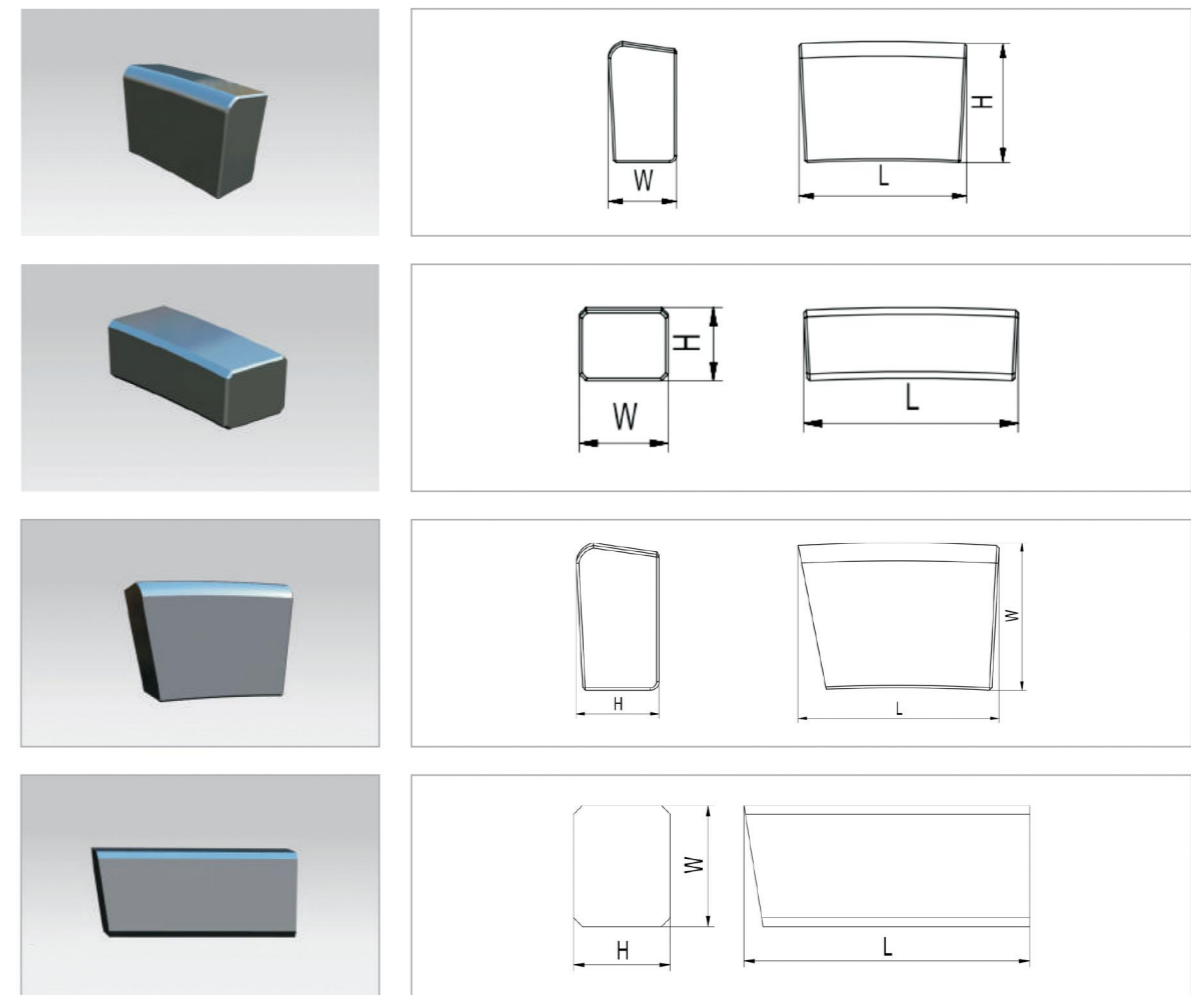

注：可按照客户要求的尺寸及形状生产  
Can be produced according to the size and shape required by the customer